



ABG™ ACTIVE BELT GRINDER™

This innovative complete solution flexibly automates the reliable surface processing of small and medium-sized work pieces. The ABG is an active sensitive belt grinder that provides a custom solution for the automated high-quality finishing of fittings, spectacle frames, implants, door handles and small cast parts for the automotive industry, etc. The floor-standing unit can be easily integrated into a robot cell. Close problematic automation gaps while at the same time improving your product quality – and create processes that are reliable, economical and perfectly reproducible.

Surface finishing processes: Grinding, deburring, polishing
All materials: Steel, aluminum, titanium, magnesium, carbon, plastic, wood, ceramics, coconut fiber...

PATENTED
TECHNOLOGY

FR
FERROBOTICS
perfect feeling

ABG™ ACTIVE BELT GRINDER™

Passive safety and high-speed control

Mechatronic actuator and sensor element offering high levels of process reliability thanks to the robust mechanical design plus integrated passive safety and high-speed control.

Force-sensitive actuator and mechanically decoupled belt tension

High level of process reliability thanks to the ingenious combination of mechatronic actuator/sensor element, lightweight design, and mechanically decoupled belt tension.

Straightforward system integration and seamless quality control

Amazingly easy to integrate using standard interfaces. The contact situation, position, and force are all fed back continuously, resulting in seamless quality control.

Maximum flexibility and adaptability

Force can be increased in accordance with individual requirements, from 10 N up to a maximum capacity of 250, 500 or 800 N. Maximum power plus individually selectable performance depending on the workpiece.

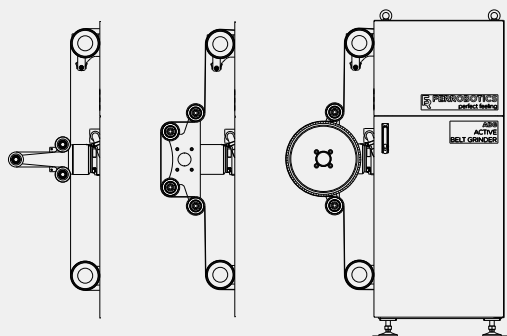

Highly dynamic

- Prevents sanding marks
- Reduces the number of process steps
- Ensures reproducible quality

Special benefits

- In-built active tolerance compensation
- Precisely adjustable process forces
- Continuous monitoring of process forces

SPECIFICATIONS

Max. force (push) [N]	10 N up to Standard 250 N (optional up to 500 N/800 N)
Stroke [mm]	48.0
Dimensions [mm]	1,170 x 770 x 1760
Dead weight [kg]	450
Power supply	AC 380 ... 500 V, 16 A, 50 – 60 Hz max. 7 bar, 30 µm, ISO 8573-1 Kl.3 (water- and oil-free)
Motor rated power [W]	4,000
Belt speed [m/s]	1 - 36
Air consumption [l/min]	20
Ambient temperature during operation [°C]	+5 ... +40
Communication Interface	Standard: Ethernet TCP/IP Optional: Ethernet IP, DeviceNet, Profibus, ProfiNet, Analog I/O